

=

lean



( , )

=

.

=

?

?

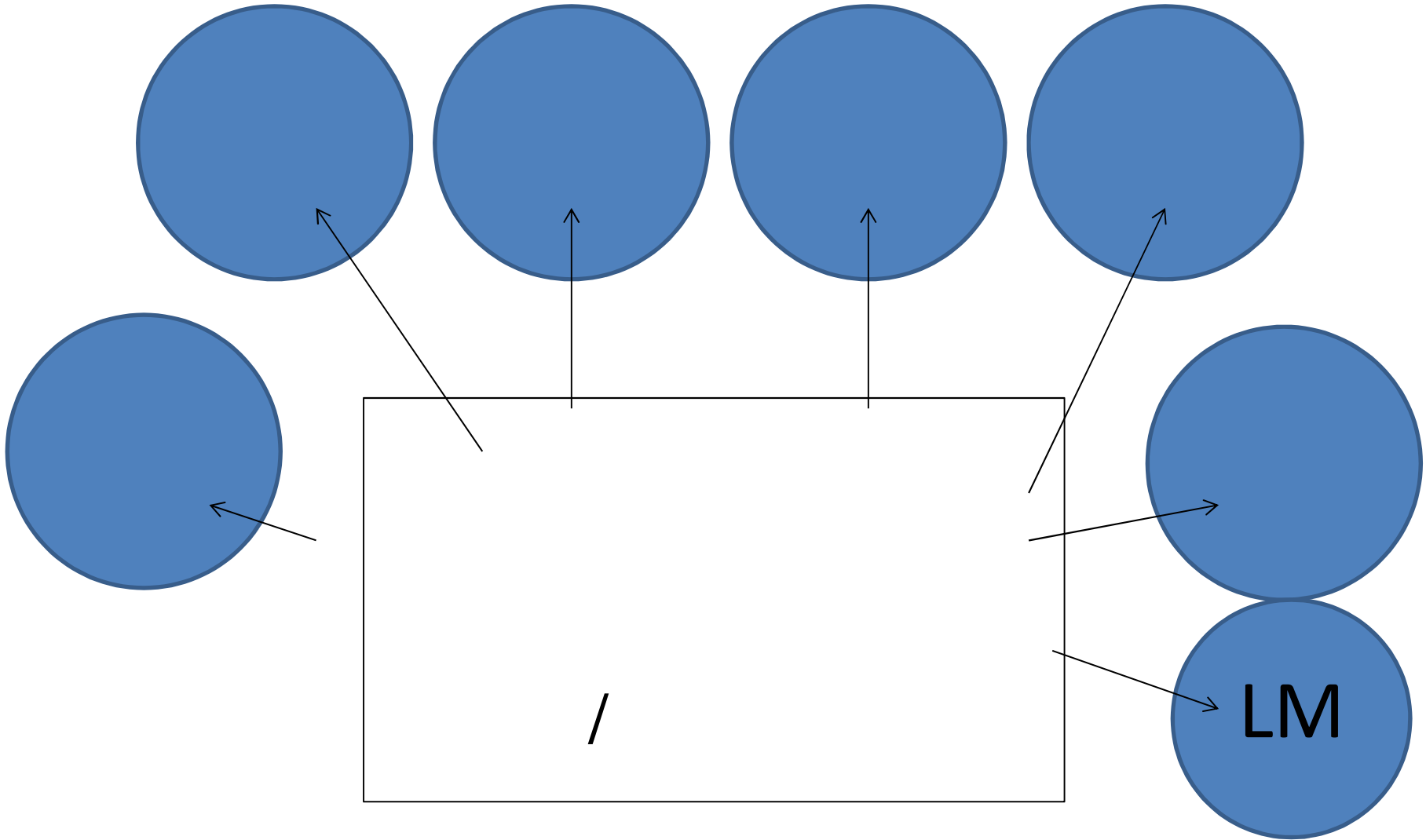

4/11/15

, ,  
, , ,

,

**2016 MRL ,CBTL ,FL ,PL**

**300,000**

**50 ,**

**25 ,**

**1,000**

( ) CBT

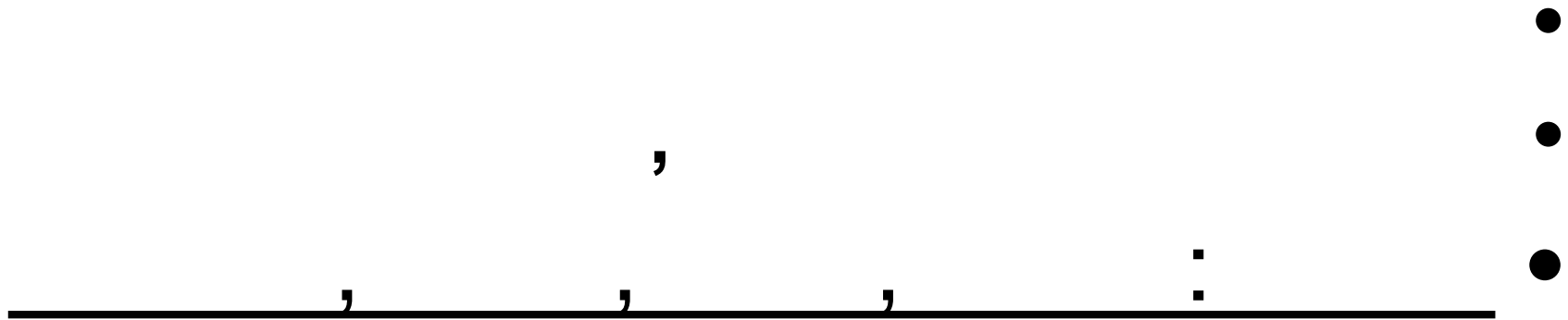

, CBT ●

Cognitive Engineering ●

, , Meta Cognition ●

(Reflection)

8 MAL - /

( - )

/

,

/

"

▪

,

**23:30 5/11/15 !**

( ) , - -

( ) , ,  
:) - -

''

''

Drive = .1

, .2

- .3

.4

- ,HIGH .5

( ) .6

MRL ,FL ,PL , , .7

( )

( )

( )

**f =**

**10**

=

-

/

—

—

—

—

—



+ = " "

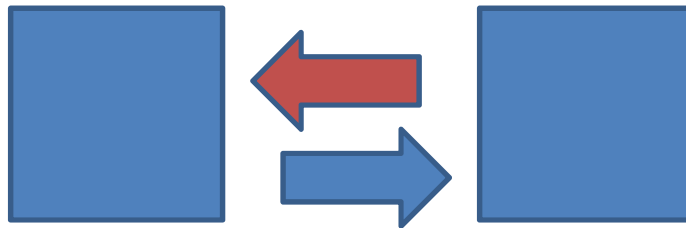
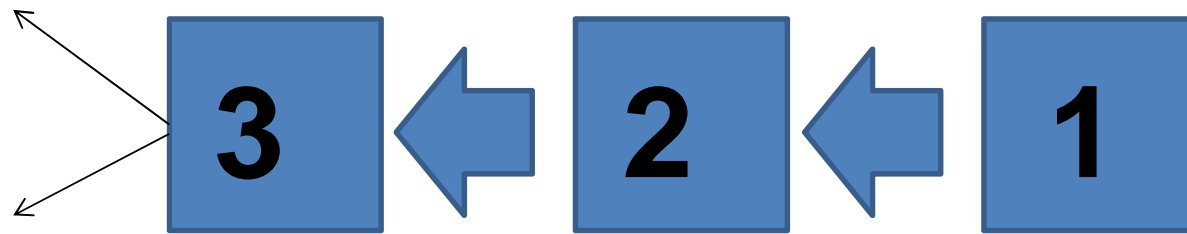

!!

!!

-

"

,

-

,

,

-

/

-

.

.

-

,

,

,

,

-



?

?

?

,

-

-

-

,

-

**2**

\*\*\*\*\*

**( )**

**.1**

**,**

**.2**

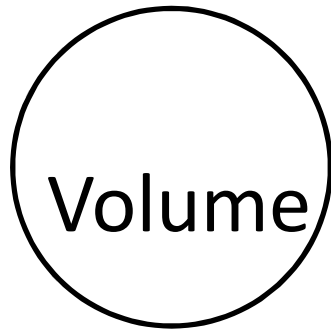

,

.

.

.

.

—

•

•

—

—

+

—

—

?

...

?

=

—

Alive / ( ) Dead

2

E - EL



F - FL

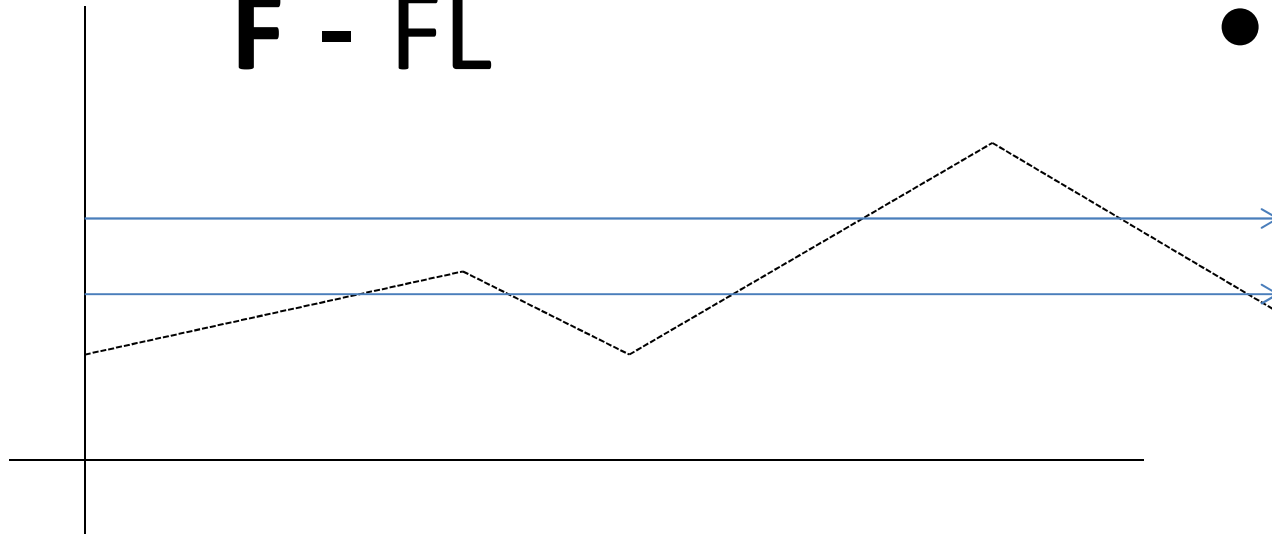

( + )

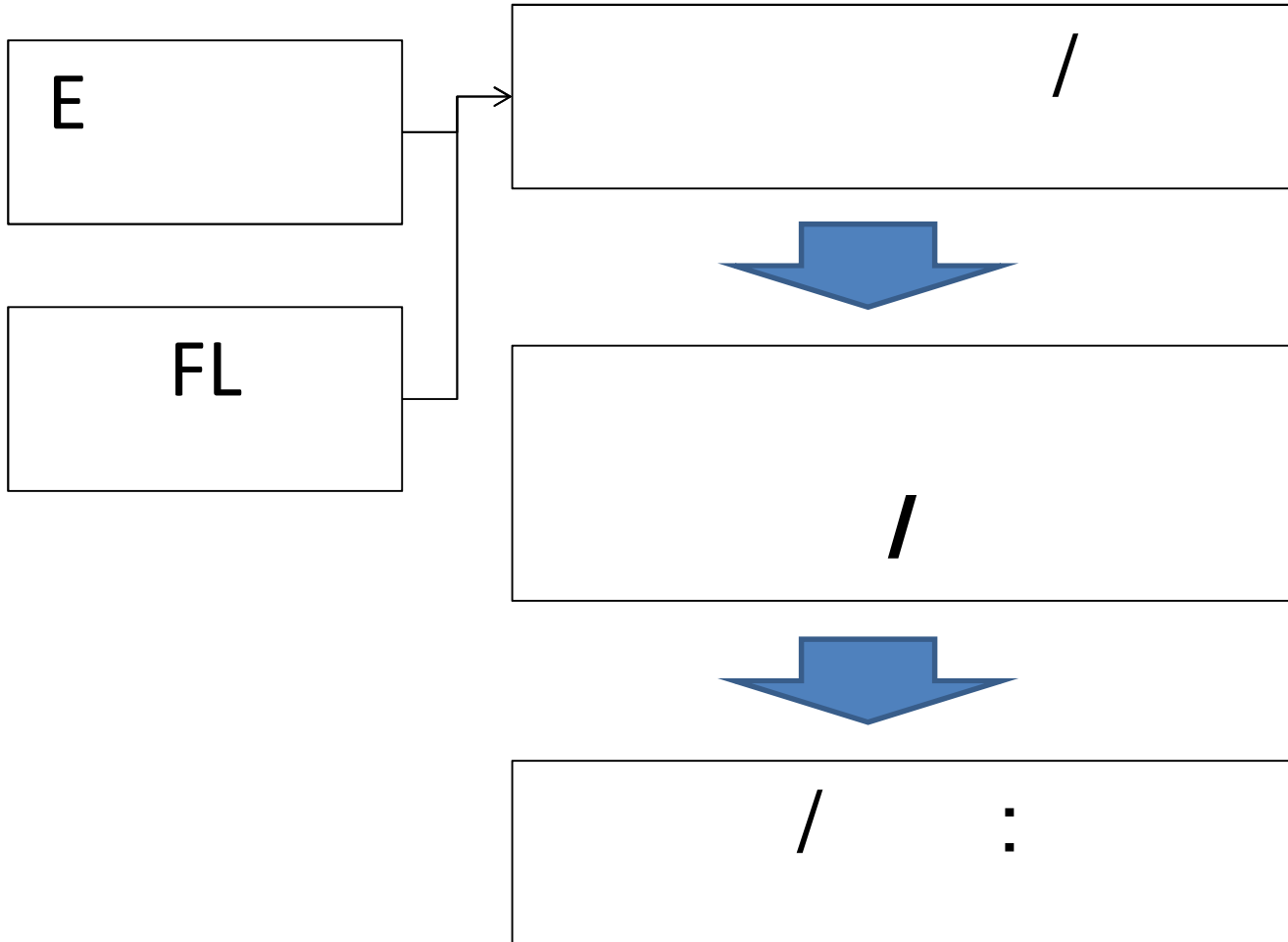

**Re-Start**

**10**



/ / ( )

, ,1 .1

.2

, , , .3

TTP , , .4

.5

,

/ .6



( / , / ) /

•

•

•

,

,

,

:

=

■ ■

■ ■

# Body management

- ,
- ,
- /
- 80%
- ,
- ,
- /
-

=

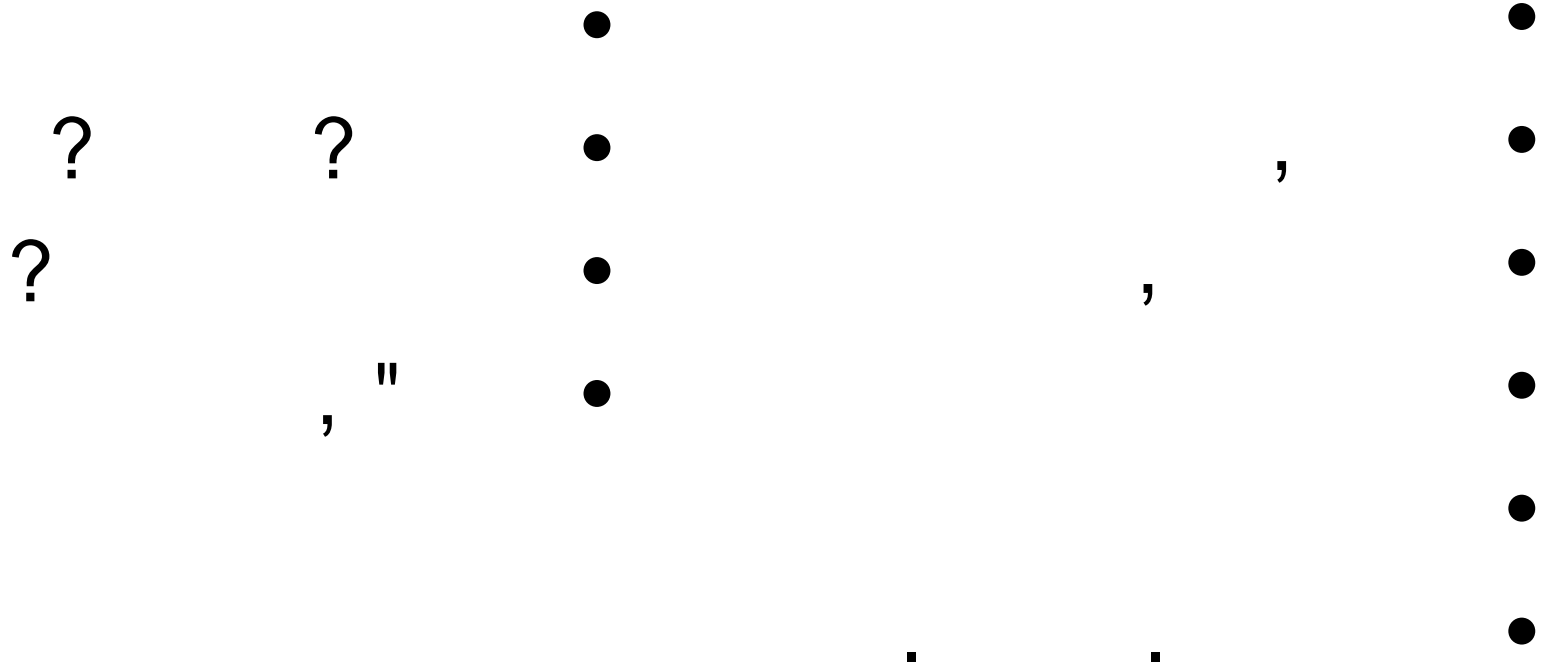

= =  
 (" ")  
 ( - . ) .1  
 .2  
 .3

100%	,
22:30 23:30	,

UP

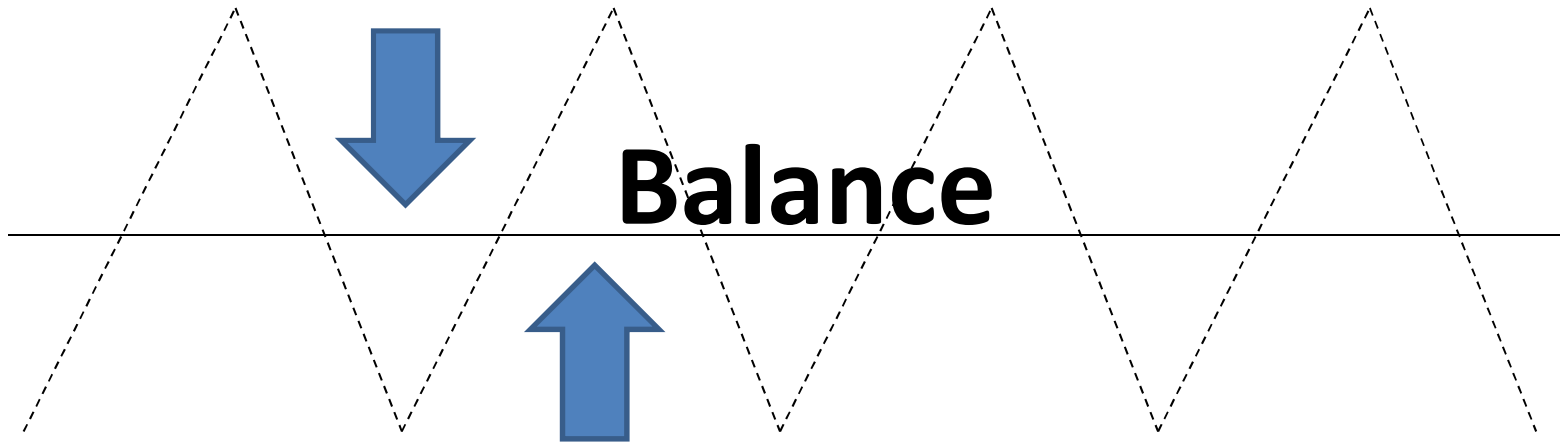

**Balance**

LOW

TTP ( )

—

▪

▪

?

•

•

•

•

•

( )

,	
▪ ▪	,
	Action ▪
▪	...?
▪	

, ,  
B A •  
( ) , •  
( ) 10 •  
( ) , •  
, / - •  
, 10 •  
, , = •



, , .1  
, , .2  
+ = .3  
, / " " .4  
, ,

1 1 + , = : .1  
( ) / / / , : .2  
, , ' : .3  
, , : .4  
, : .5  
, : .6

? 8 7

/

/

•

•

•

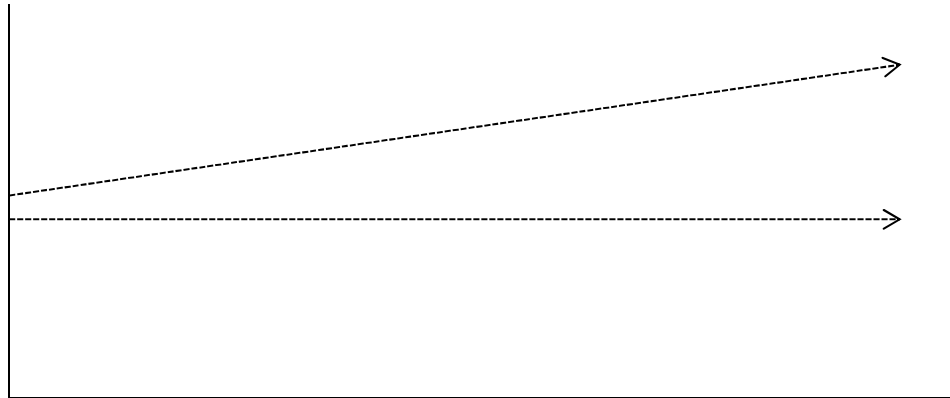

,CBTL

,

!

,PL

,

,Alive

Dead

,

,

,1

,

,

,

,

		-	
			.1
		20 *	.2
/	10		.3
		+	
		/	.4
	-	/	.5
		,	.6
("	"	)	.7
		,	.8

# 2016

MRL

PL

-5

,

:

:

3

.1

"

.

.

.

,

-

.2

(CBTL)

.3

...

!!!

-

158.co.il    eran@158.co.il